

Mounting Instructions
LANCOM AirLancer
ON-Q360ag

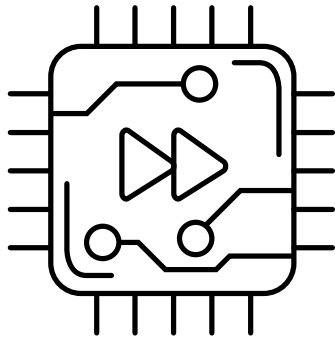

Attaching the antenna bracket by wall mounting

In the case of wall mounting, attach the antenna bracket to the wall with the enclosed bolts. You may need to drill the holes first and insert dowels.

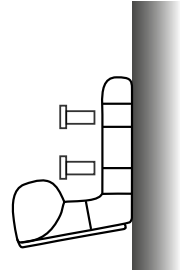

Attaching the antenna bracket by pole mounting

In the case of pole mounting, use screw clamps to attach the antenna bracket directly to the pole.

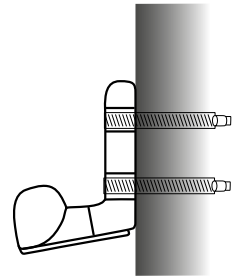

Attaching the antenna arm to the antenna

When attaching the antenna arm to the antenna, please ensure that there is a close fit between them. Make use of the pin on the antenna arm and the matching recess in the antenna. Finally, use the locking screw to secure the antenna arm to the antenna.

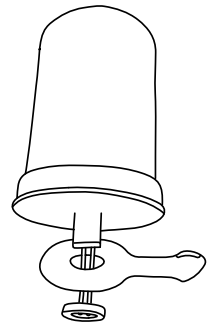

Important

Mounting the antenna upside down

If the antenna will be mounted outdoors and with the cables exiting upwards, it is essential to have a good seal by sticking the insulation disk to the antenna before attaching it to the antenna arm.

Attaching the antenna to the antenna bracket

The antenna is attached to the antenna bracket by means of the antenna arm. To do this, place the antenna-arm joint socket onto the joint head of the antenna bracket. Tighten this joint with the wing screw or hexagon socket screw supplied. Whichever screw you use, please be sure to use the washer supplied.

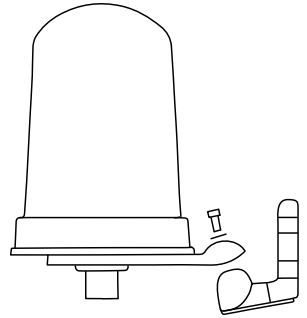

Attaching the antenna to a suspended ceiling

This requires a 3-cm diameter hole in the suspended ceiling.

First stick the insulation disk to the antenna. This acts as a washer and protects the ceiling and the antenna. Insert the cables and the screw thread through the hole in the ceiling. Then screw the locking screw onto the screw thread and tighten it.

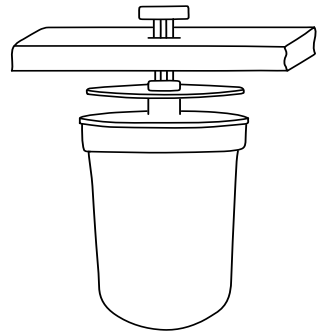

Important information

Working responsibly with high frequencies

For compliance with protection requirements of the EU directive 2014/53 and EN 62479 in relation to the basic limits for human safety in electromagnetic fields and the “FCC Policy on Human Exposure to Radiofrequency Electromagnetic Fields”, it is essential to configure the accurate antenna gain value in the Wi-Fi router or Wi-Fi access point.

Electrical and electronic equipment law

In the interests of recycling, please do not dispose of electrical and electronic waste in your household garbage. Ensure that your electrical and electronic waste is disposed of in accordance with the regulations in your country.

Proper handling of antenna cables

Antenna cables are sensitive RF cables. During installation it is important that the cables are not creased, and bent as little as possible, otherwise the antenna will suffer a loss of performance. Do not coil the antenna cable in tight loops.

Antenna gain and terminating unused antenna connectors on the access point

It is essential for unused antenna connectors on the access point to be terminated with the supplied rod antenna. The terminating resistor supplied with the adapter AirLancer AN-RPSMA-NJ is suitable for use with indoor access points. In addition, you must disable the unused antenna connectors in LCOS (changing the antenna grouping of the respective WLAN module), and configure the antenna gain of the antenna. The settings can be found in LANconfig under: Configuration > Wireless LAN > General > Physical WLAN settings > Radio

Radiation patterns

